



METEOROLOGICAL INSTRUMENTS

INSTRUCTIONS

WIND SYSTEM CALIBRATION

RECOMMENDED CALIBRATION INTERVAL,
PROCEDURE, AND TEST EQUIPMENT

MODEL 18860-90

INCLUDES INSTRUCTIONS FOR THE FOLLOWING

MODEL 18802/18811 ANEMOMETER DRIVE
MODEL 18112/18212 VANE ANGLE FIXTURE
MODEL 18310/18312 TORQUE DISC
MODEL 18331 VANE TORQUE GAUGE



WIND SYSTEM CALIBRATION EQUIPMENT

With Recommended Calibration Interval, Procedure, and Test Equipment

Periodic maintenance of YOUNG sensors is necessary to maintain published specifications. This manual will describe recommended calibration intervals and procedures, and provide instructions for the use of YOUNG calibration equipment.

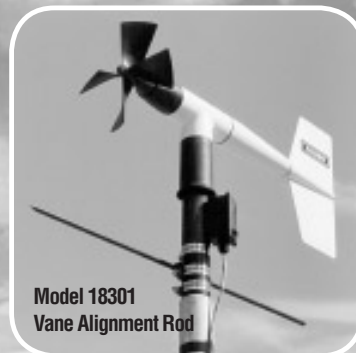

RECOMMENDED CALIBRATION INTERVAL

	Operational Accuracy	Research Accuracy
	<u>WS ± 0.5 m/s</u> <u>WD ± 5°</u>	<u>WS ± 0.3 m/s</u> <u>WD ± 3°</u>
TOWER CHECK	6 months	3 months
TRAILER CHECK	12 months	6 months
LABORATORY CHECK	24 months	12 months
MANUFACTURER CHECK	N/A	24 months
	Manufacturer's standard calibration is within operational accuracy limits. Perform tower check at initial installation. Tower check and trailer check intervals are recommended minimums for optimum performance.	Sensor requires wind tunnel calibration by manufacturer, or other recognized calibration laboratory, prior to initial installation. Tower check and trailer check intervals are recommended minimums. Perform tower check at initial installation.

OUTPUT SIGNAL MEASUREMENTS

Wind speed signals vary among sensors. The signals may be frequency related for magnet/coil and photochopper transducers or voltage related for tachometer generator transducers. Wind direction signals from potentiometer transducers are voltage related and are dependent upon stable excitation voltage. To monitor wind speed and direction signals, use a suitable indicator. It may be a frequency meter, voltmeter, calibrated wind indicator, data logger with display, or some combination of these instruments. As a general rule the resolution of the indicator should be equal to the smallest unit being measured and the accuracy of the indicator should be 5 to 10 times better than that required by the calibration. If necessary quantify and account for any additional error introduced by the indicating device.

WIND SPEED SENSOR TYPES

The following procedures refer to a propeller type wind speed sensor, however they are equally applicable to a cup wheel type sensor. To check wind speed threshold of a cup wheel anemometer using the torque disc, hold or mount the sensor with the cup wheel shaft horizontal.

TOWER CHECK

Perform tower check for each initial installation regardless of prior calibration interval.

	PROCEDURE	EQUIPMENT
Wind Speed Threshold:	In calm weather blow gently on propeller. Watch for obvious high torque or irregular rotation.	None
Wind Speed Signal:	Remove propeller or cup wheel. Drive shaft at known rpm, representing mid range of sensor. Compare output signal to established calibration.	Anemometer Drive
Wind Direction Threshold:	In calm weather blow gently on vane. Watch for obvious high torque or irregular motion.	None
Wind Direction Signal:	Visually align vane with known reference. Compare output signal. Align vane with additional reference points or cardinal points marked on housing. Compare output signal to established calibration.	Survey of visible landmarks, accurate magnetic compass, or solar noon orientation.

TRAILER CHECK

Sensors are removed from tower and connected to signal conditioning modules with sensor cable patch cords.

	PROCEDURE	EQUIPMENT
Wind Speed Threshold:	Remove propeller. Set torque disc for proper torque according to table and curves supplied. Install torque disc on propeller shaft and check rotation of disc. See instructions on torque disc drawing.	Propeller Torque Disc
Wind Speed Signal:	Remove propeller. Drive shaft at 200 rpm. Check output for measurable signal. Drive shaft at rpm representing mid range of sensor. Compare output signal to established calibration.	Anemometer Drive
Wind Direction Threshold:	Hold or mount sensor on desk top with fin horizontal to check vane balance. Adjust if required. After balancing vane assembly, mount sensor on bench stand on level surface. Determine proper torque according to table and curves supplied. Place torque gauge on vane housing and apply steady force to end of leaf spring. Record maximum torque value for both CW and CCW rotation. See instructions on torque gauge drawing.	Vane Torque Gauge Vane Angle Bench Stand
Wind Direction Signal:	Mount sensor on Bench Stand. Rotate fixture through 360 degrees comparing output signal at 30 degree intervals.	Vane Angle Bench Stand.

LABORATORY CHECK

Sensors and signal conditioning modules are removed from the field site and inspected at a calibration lab equipped with appropriate fixtures and test equipment and operated by a qualified instrument technician.

	PROCEDURE	EQUIPMENT
Wind Speed Threshold:	Remove propeller. Set torque disc for proper torque according to table and curves supplied. Install torque disc on propeller shaft and check rotation. See instructions on torque disc drawing.	Propeller Torque Disc
Wind Speed Signal:	Drive propeller shaft at 200 rpm, observe output on oscilloscope for minimum signal level and proper form. Drive propeller shaft at a minimum of three other rpm values throughout the working range of the propeller, checking output signal at each speed. Compare to established calibration.	Oscilloscope Anemometer Drive
Wind Direction Threshold:	Check vane balance and adjust if required. After balancing vane assembly, mount sensor on bench stand on level surface. Determine proper torque according to table and curves supplied. Place torque gauge on vane housing and apply steady force to end of leaf spring. Record maximum torque value for both CW and CCW rotation. See instructions on torque gauge drawing.	Vane Torque Gauge Vane Angle Bench Stand
Wind Direction Signal:	Install sensor on vane angle fixture. Check output signal at 30° intervals with additional checks at 340°, 350°, and 355°..	Vane Angle Fixture.

MANUFACTURER CHECK

Return sensors to manufacturer or other recognized calibration lab. These tests are performed at manufacturer's facilities or calibration lab facilities on a fee basis.

	PROCEDURE	EQUIPMENT
Wind Speed Threshold:	Check and adjust propeller balance. Install sensor on threshold fixture. Measure and record starting and stopping wind speed values.	Threshold Fixture
Wind Speed Signal:	Install sensor in wind tunnel. Measure and record output signal at 1, 2, 3, 4, 5, 6, 8, 10, 12, 14, 16, 20, and 25 and 30 m/s. Tabulate wind tunnel speed vs. sensor output. Calculate and record slope and intercept.	Wind Tunnel Facility
Wind Direction Threshold:	Measure vane torque and record equivalent threshold wind speed.	Vane Torque Fixture
Wind Direction Signal:	Install sensor on master vane angle fixture. Measure and record output signal through complete 360° rotation. Measure and record electrical function angle.	Master Vane Angle Fixture



MODEL 18802 / 18811
SELECTABLE SPEED
ANEMOMETER DRIVE



SPECIFICATIONS

Operating Range	200 - 15,000 RPM	(18802)
	20.0 - 990.0 RPM	(18811)
Resolution	1 RPM	(18802)
	0.1 RPM	(18811)
Power Requirement:	12 to 30 VDC	
	(2W nominal, 6W max)	
Battery Power:	(2) 9-V	

INTRODUCTION

The YOUNG Selectable Speed Anemometer Drive provides a convenient and accurate way to rotate an anemometer shaft at a known rate. The device consists of a control/display unit and a variable speed motor with integral high-resolution optical encoder.

Two models are available: Model 18802 has an operating range of 200 to 15,000 RPM for use with propeller type anemometers. Model 18811 has a lower RPM range for use with cup type anemometers. The control unit is the same in each case. High and low speed motors are available separately, permitting operation in both speed ranges with a single display unit.

The control unit automatically senses motor assembly type (high or low speed) and adjusts display and controlling circuits automatically. Operating parameters for each motor type include MAX & MIN RPM, STEP SIZE, and 9 PRESET speeds. Settings for these parameters are saved when power is off.

A front panel CW-CCW switch selects rotation direction (as seen facing anemometer). Motor speed is selected using the UP-DOWN keys. The display shows the target and actual RPM. Motor rotation and measurement are referenced to a crystal oscillator for stability and accuracy. Current limiting circuits protect the motor from damage due to overload or stalling.

The 18802 is powered from an AC wall adapter (included). For completely portable operation, two internal 9-V batteries power the unit. Use lithium type for longest life. When batteries are low, the controller stops the motor and alerts the user on the display.

OPERATION

For proper operation, the coupling on the motor must be carefully aligned with the anemometer shaft. Misalignment, particularly at low RPM rates, causes instability and stalling.

Alignment fixtures included with the device allow the motor to be attached directly to YOUNG anemometers. Attach the alignment fixture to the sensor as follows:

- 1) Remove propeller or cup-wheel from anemometer shaft and attach coupling disc to shaft.
- 2) Mount clamp and bar fixture on sensor and gently tighten clamp. **Do not overtighten!**
- 3) Attach motor to fixture. Carefully align anemometer and motor coupling and gently tighten motor clamp. **DO NOT OVERTIGHTEN.**
- 4) Turn unit ON and use the UP-DOWN keys to set target RPM.
- 5) Within several seconds display should show actual RPM within ± 1 RPM of target setting. If not, carefully adjust alignment until display shows proper value. This can be performed while motor is running.

If the calibrating unit is used with an anemometer which does not fit the alignment fixture, the motor may be held in place by hand. Good results can be achieved if the motor and anemometer shafts are well aligned.

MENU

Access the Setup Menu by pressing and holding the MENU key for about five seconds. The motor will stop and the Setup Menu will appear on the display. Each menu item and its function is listed below.

Use the UP-DOWN keys to scroll between items on the menu list. To EDIT a value, press the MENU key then use the UP-DOWN keys to change it. When you are finished editing, press MENU again. To return to OPERATE mode, repeatedly press the UP key until OPERATE appears on the display then press MENU. The 18802 stores the new settings and within several seconds will begin operating at its lowest speed. **You MUST return to OPERATE mode to retain new settings.**

MENU ITEM	DESCRIPTION
OPERATE	Press MENU to return to OPERATE mode. You MUST return to OPERATE mode to retain new settings.
MAX RPM	Maximum RPM allowed during operation. Once the maximum is reached, pressing the UP key has no effect. Limited to operating range of motor.
MIN RPM	Minimum RPM allowed during operation. Once the minimum is reached, pressing the DOWN key has no effect. Limited to operating range of motor.
STEP SIZE	The number of RPM added or subtracted when the UP-DOWN keys are pressed to change target RPM during operation.
PRESET	YES/NO determines whether preset RPM settings are used. If YES, pressing the UP-DOWN keys selects preset speeds 1 through 9. If NO, UP-DOWN changes speed by STEP SIZE increments.
PRESET1-9	Preset RPM values. Each PRESET may be set to any value in operating range of motor.

EMC COMPLIANCE

This device complies with Part 15 of the FCC Rules. Operation is subject to the following two conditions: (1) this device may not cause harmful interference, and (2) this device must accept any interference received, including interference that may cause undesired operation.

This equipment has been tested and found to comply with the limits for a Class A digital device, pursuant to part 15 of the FCC Rules. These limits are designed to provide reasonable protection against harmful interference when the equipment is operated in a commercial environment. This equipment generates, uses, and can radiate radio frequency energy and, if not installed and used in accordance with the instruction manual, may cause harmful interference to radio communications. Operation of this equipment in a residential area is likely to cause harmful interference in which case the user will be required to correct the interference at his own expense.

This ISM device complies with Canadian ICES-001.

Cet appareil ISM est conforme à la norme NMB-001 du Canada. EN55011/CISPR 11, Group 1, Class B device.

Class B equipment is suitable for use in domestic establishments and in establishments directly connected to a low voltage power supply network which supplies buildings used for domestic purposes.

To meet EMC Compliance, a YOUNG 18500 ferrite choke must be installed on the DC power cable. The cable must pass through the center hole of the choke at least 4 times, creating 3 loops around the outside as shown below.

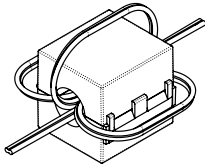

WARRANTY

This product is warranted to be free of defects in materials and construction for a period of 12 months from date of initial purchase. Liability is limited to repair or replacement of defective item. A copy of the warranty policy may be obtained from R. M. Young Company.

CE COMPLIANCE

This product has been tested and complies with European CE requirements for the EMC Directive. Please note that shielded cable must be used.



Anemometer Drive

Model 18802 (200 to 15,000 RPM) / Model 18811 (20 to 990 RPM)

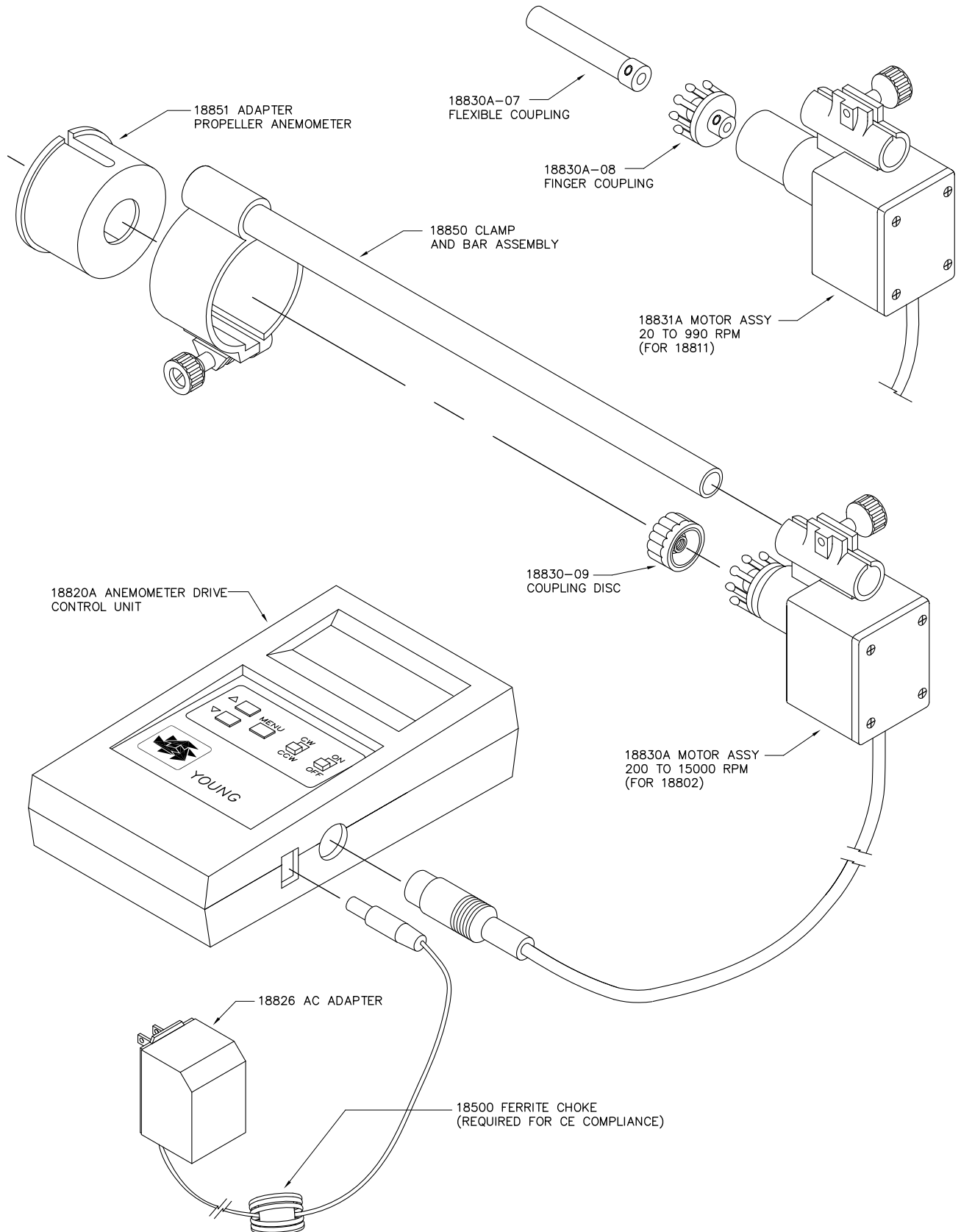



Propeller / Cup Wheel Torque Disc

Model 18310 / Model 18312

The Propeller Torque Disc checks anemometer bearing torque with 0.1 gm/cm resolution. The disc temporarily replaces the propeller for torque measurement or simple yet accurate pass/fail checks. The following chart relate torque to propeller threshold with limits for acceptable bearing performance.

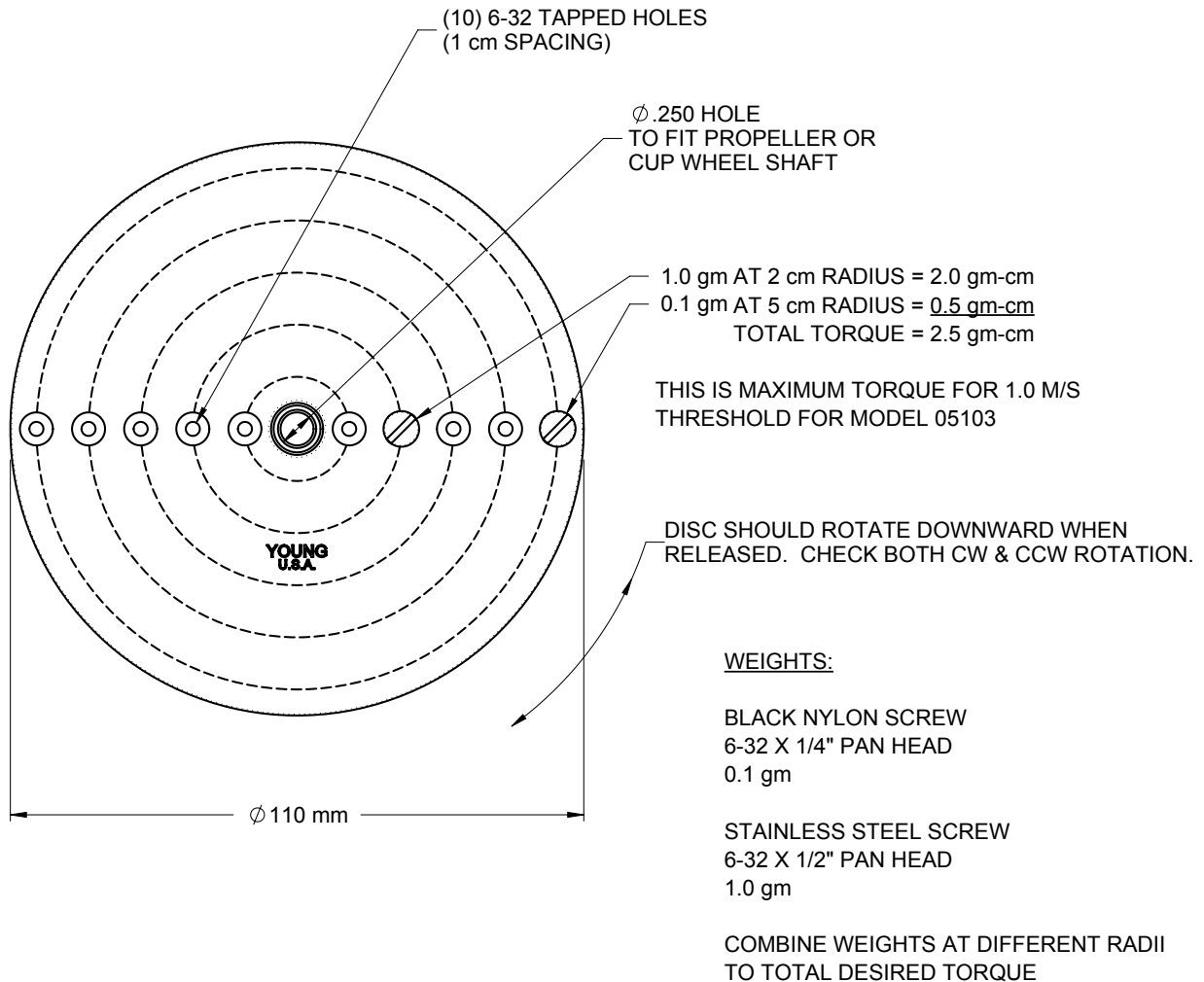

1. Select torque value for type of instrument to be checked and desired maximum threshold from table.
2. Add weights to torque disc to equal this torque value.
3. Remove propeller, or cup wheel, from anemometer and install torque disc with weights in horizontal position, disc should rotate downward when released.
4. Free rotation indicates good bearing/transducer condition.
5. Failure to rotate indicates need for service.



Propeller / Cup Wheel Torque Disc

TYPICAL TORQUE VALUES

For Verifying Anemometer Bearing and Transducer Condition

Instrument (Standard Models)	Sensor	Transducer	¹ New Instrument		² Max torque for threshold of:	
			Torque gm-cm	Threshold m/s	0.5 m/s gm-cm	1.0 m/s gm-cm
03101-5A Wind Sentry Anemometer	03110	AC Coil	0.3	0.5	0.3	1.0
05103 Wind Monitor	08234	AC Coil	2.4	1.0		2.6
05106 Wind Monitor - MA	08234	AC Coil	2.9	1.1		
05108 Wind Monitor - HD	08214	AC Coil	2.9	1.1		
05305 Wind Monitor - AQ	08254	AC Coil	0.3	0.3	1.0	3.8
09101 Wind Monitor - SE	08234	AC Coil	2.4	1.0		2.6
09305 Wind Monitor - AQ - SE	08254	AC Coil	0.3	0.3	1.0	3.8
12102 Cup Anemometer	12170C	2400 mV Tach-Gen	0.4	0.5	0.4	1.4
12102D Cup Anemometer	12170C	Photo Chopper	0.1	0.3	0.4	1.4
27106 Propeller Anemometer	08274	500 mV Tach-Gen	0.5	0.3	1.3	5.0
27106T Propeller Anemometer	08254	500 mV Tach-Gen	0.5	0.4	1.0	3.8
	08274	Photo Chopper	0.3	0.2	1.3	5.0

NOTES:

1. New instrument torque and threshold specifications are maximum values
2. Values shown are maximum torque to maintain instrument threshold at or below 0.5 m/s and 1.0 m/s respectively.
3. EPA and NRC instrument specifications designate 0.5 m/s wind speed starting threshold. ASTM D5096-90 "Standard Test Method for Determining the Performance of a Cup Anemometer or Propeller Anemometer" defines "starting threshold" and outlines a method for its determination.

SENSORS:

03110	Wind Sentry 75 cm Cup Wheel Assembly
08214	18 X 50 cm ASA Propeller (ASA)
08234	18 X 30 cm Polypropylene Propeller (PP)
08254	20 X 30 cm Carbon Fiber Thermoplastic Propeller (CFT)
08274	22 X 30 cm Expanded Polystyrene Propeller (EPS)
12170C	100 cm Cup Wheel Assembly

STANDARD BEARINGS:	
05103 Wind Monitor 09101 Wind Monitor-SE:	Stainless Steel Body and Bearings Double Teflon seals Lubrication: LY-48 wide temperature range grease
05106 Wind Monitor - MA 05108 Wind Monitor - HD	Ceramic Body with Stainless Steel Bearings Double Teflon seals Lubrication: 10% SRI 2 Grease
03101-5A Wind Sentry Anemometer 05305 Wind Monitor-AQ 09305 Wind Monitor-AQ-SE:	Stainless Steel Body and Bearings Double metal shields Lubrication: LOI instrument oil
All other models -	Stainless Steel Body and Bearings Double Teflon seals Lubrication: LOI instrument oil



Propeller / Cup Wheel Torque Disc

APPROXIMATE PROPELLER / CUP WHEEL TORQUE VS WIND SPEED

(Near Threshold / Non-Rotating)

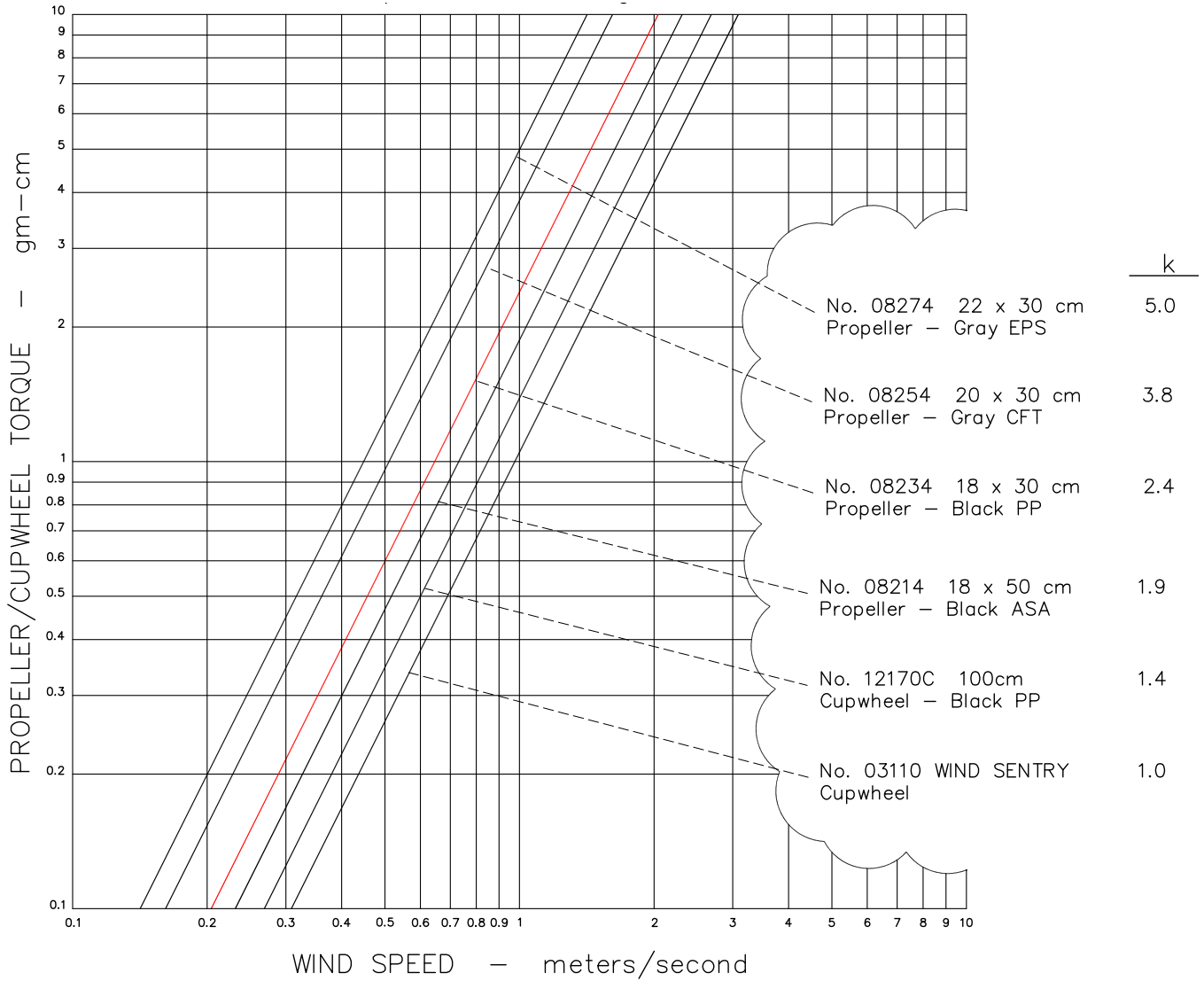

$$T = kU^2 \quad U = \sqrt{T/k}$$

T = Torque (gm-gm)
 U = Wind Speed (meters/second)
 k = Constant



MODEL 13881 VANE TORQUE GAUGE

Verify Rotor Bearing and Transducer Condition

The Vane Torque Gauge checks vane bearing torque of the Wind Monitor family of sensors. Slip the fixture over the main housing and make simple yet accurate vane torque measurements. The following chart relates vane torque to vane threshold and provides limits for acceptable bearing performance.

Gauge Usage:

- 1) Determine torque value for type of instrument to be checked and find maximum threshold from table.
- 2) Install gauge on top of instrument as shown below, with target directly over the bearing centerline.
- 3) With instrument mounted vertical and plum with no air movement apply steady force at end of leaf spring.
- 4) Vane should rotate through 360 degrees without exceeding selected torque value.
- 5) Free rotation indicates good bearing/transducer condition.
- 6) Excess torque indicates need for service.

THREAD ATTACHED TO END OF LEAF SPRING PROVIDES CONVENIENT MEANS OF APPLYING STEADY FORCE.

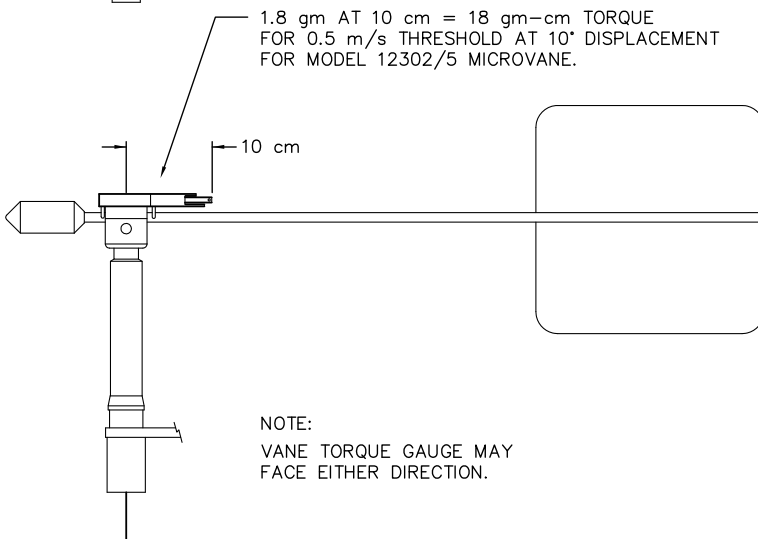
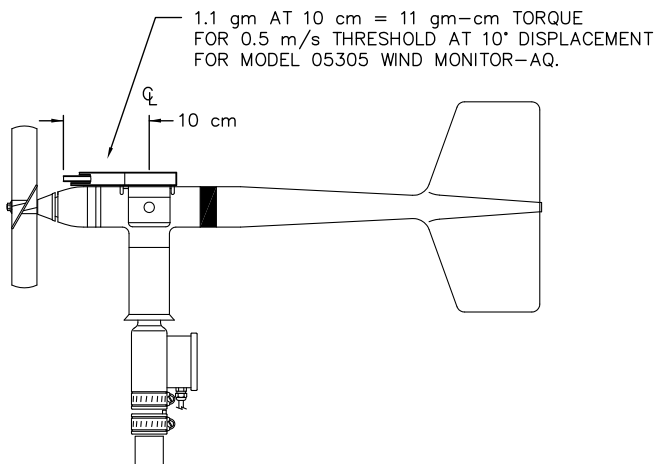

NOTE:
VANE TORQUE GAUGE MAY
FACE EITHER DIRECTION.

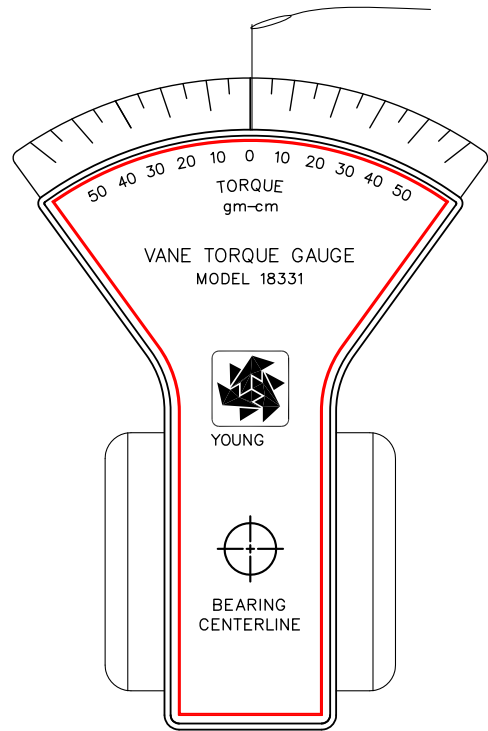



VANE TORQUE GAUGE

TYPICAL VALUES

For Checking Anemometer Bearing and Transducer Condition

Instrument (Standard Models)	¹ New Instrument		^{2,3} Max torque for threshold of:	
	Torque gm-cm	Threshold m/s @ 10°	0.5 m/s @ 10° gm-cm	1.0 m/s @ 10° gm-cm
05103 Wind Monitor	30	1.1		
05106 Wind Monitor - MA	30	1.1		
05108 Wind Monitor - HD	30	1.1		
05305 Wind Monitor - AQ	9	0.5	11	40
09101 Wind Monitor - SE	30	1.1		
09305 Wind Monitor - AQ - SE	9	0.5	11	40
12302/5 Microvane	11	0.4	18	66

NOTES:

1. New instrument torque and threshold specifications are maximum values
2. Values shown are maximum torque permitted to maintain instrument threshold at or below 0.5 m/s and 1.0 m/s respectively at 10° displacement.
3. EPA and NRC instrument specifications designate windvane threshold measurement at 10° displacement from equilibrium position. ASTM D5366-93 "Standard Test Method for Determining the Dynamic Performance of a Wind Vane" defines "starting threshold" and outlines a method for its determination.

STANDARD BEARINGS:	
05103 Wind Monitor 09101 Wind Monitor-SE:	Stainless Steel Body and Bearings Double Teflon seals Lubrication: LY-48 wide temperature range grease
05106 Wind Monitor - MA 05108 Wind Monitor - HD	Ceramic Body with Stainless Steel Bearings Double Teflon seals Lubrication: 10% SRI 2 Grease
05305 Wind Monitor-AQ 09305 Wind Monitor-AQ-SE:	Stainless Steel Body and Bearings Double metal shields Lubrication: LOI instrument oil
All other models -	Stainless Steel Body and Bearings Double Teflon seals Lubrication: LOI instrument oil



Vane Torque Gauge

APPROXIMATE VANE TORQUE AT 10° OFFSET vs WIND SPEED

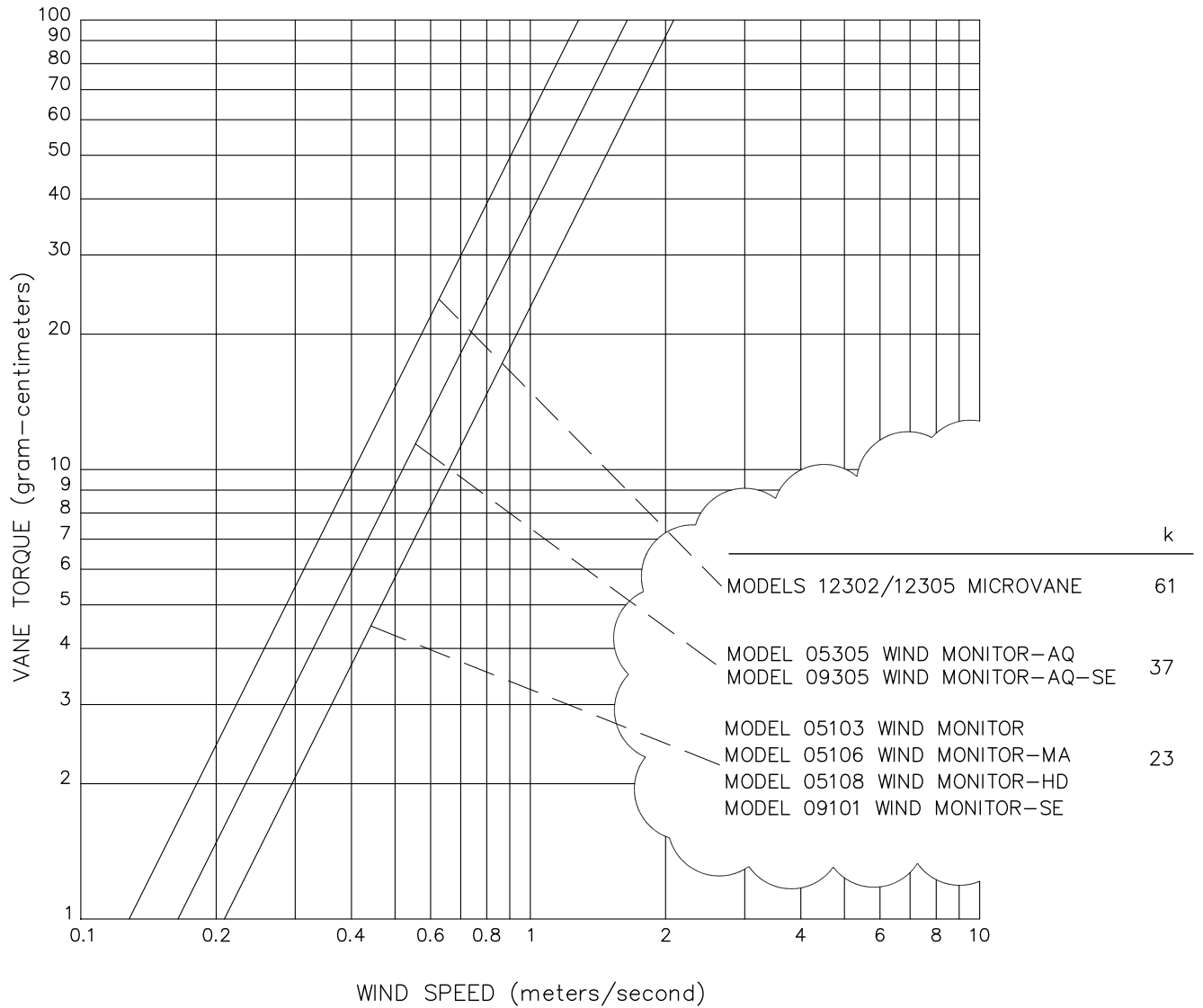

VANE OFFSET 10° FROM TRUE WIND DIRECTION

$$T = kU^2 \quad U = \sqrt{T/k}$$

T = TORQUE (gm-cm)

k = CONSTANT

U = WIND SPEED (meters/second)



VANE ANGLE BENCH STAND / FIXTURE TOWER MOUNT

For verifying sensor direction output

Model 18112 Vane Angle Bench Stand is used for bench top wind direction calibration of the Wind Monitor family of sensors. The mounting post engages the direction orientation notch on the Wind Monitor. An easy to read pointer indicates 0 to 360° with 1/2° resolution.

Model 18212 Vane Angle Fixture - Tower Mount allows sensor direction calibration on location on the tower. The fixture is temporarily placed on the tower between the Wind Monitor and its tower mounting. Index keys and notches are engaged to preserve direction reference.

Note:

After removal of the Wind Monitor, the Tower Mount Vane Angle Fixture is installed with the South alignment notch engaging the index key on the Orientation Ring. The Wind Monitor is then reinstalled on the Vane Angle Fixture with its South alignment notch engaging the Index Key on the fixture. After checking the Vane output against the Azimuth angle, the fixture is removed and the Wind Monitor is reinstalled, engaging the index key on the orientation ring, thus the original direction reference is not disturbed.

