

## 1.1.2.4 Low - Medium Power Thermal Sensors - Apertures to 35mm

### 30mW to 150W

#### Features

- Convection air cooled
- CW to 30W or 50W, intermittent to 150W
- Ø17.5mm and Ø35mm apertures
- Measure powers up to 4000W by short exposures to laser

30(150)A-BB-18



30(150)A-LP2-18

L50(150)A-BB-35  
L50(150)A-PF-35

L50(150)A-LP2-35



Model	30(150)A-BB-18	30(150)A-LP2-18	L50(150)A-BB-35	L50(150)A-LP2-35	L50(150)A-PF-35
Use	General purpose	High power density and long pulse lasers	General purpose	High power density and long pulse lasers <sup>(b,c)</sup>	Short pulse lasers
Absorber Type	Broadband	LP2	Broadband	LP2	PF
Spectral Range $\mu\text{m}$	0.19 - 11	0.25 - 2.2	0.19 - 11	0.25 - 2.2	0.15-20
Absorption	>85%	>94% from 0.25 to 1.1 $\mu\text{m}$	>85%	>94% from 0.25 to 1.1 $\mu\text{m}$	>85%
Aperture mm	Ø17.5mm	Ø17.5mm	Ø35mm	Ø35mm	Ø35mm
Power Mode					
Power Range	30mW - 150W	30mW - 150W	100mW - 150W	100mW - 150W <sup>(b,c)</sup>	100mW - 150W
Maximum Intermittent Power W	150W for 1.5min, 100W for 2.2min, 30W continuous		150W for 1.5min, 100W for 2.5min, 50W continuous	150W for 1.5min, 100W for 2.5min, 50W continuous	150W for 1.5min, 100W for 2.5min, 50W continuous
Power Scales	150W / 30W / 3W	150W / 30W / 3W	150W / 50W / 5W	150W / 50W / 5W	150W / 50W / 5W
Power Noise Level	2mW	2mW	4mW	4mW	4mW
Maximum Average Power Density kW/cm <sup>2</sup>	12 at 150W 20 at 30W	33 at 150W 50 at 30W	12 at 150W 17 at 50W	33 at 150W 50 at 50W	3
Response Time with Meter (0-95%) typ. s	1.2	1.2	2	2	2
Calibration Uncertainty $\pm\%$	1.9	1.9	1.9	1.9	1.9
Power Accuracy $\pm\%$	3 <sup>(g)</sup>	3 <sup>(g)</sup>	3 <sup>(g)</sup>	3 <sup>(g)</sup>	4 <sup>(d)</sup>
Linearity with Power $\pm\%$	1	1	1	1	1
Energy Mode					
Energy Range	20mJ - 100J	20mJ - 300J	40mJ - 300J	40mJ - 3000J	50mJ - 300J
Energy Scales	100J / 30J / 3J	300J / 30J / 3J	300J / 30J / 3J	3000J / 300J / 30J / 3J	300J / 30J / 3J
Minimum Energy mJ	20	20	40	40	50
Maximum Energy Density J/cm <sup>2</sup>					Single <sup>(e)</sup> 10-50Hz <sup>(e)</sup>
<100ns	0.3	0.1	0.3	0.1	3 <sup>(f)</sup> 1.5
0.5ms	5	50	5	50	7 7
2ms	10	130	10	130	15 15
10ms	30	400	30	400	40 40
>300 ms	NA	NA	NA	See below <sup>(b,c)</sup>	NA NA
Cooling	convection	convection	convection	convection	convection
Fiber Adapters Available (p. 119)	ST, FC, SMA, SC	ST, FC, SMA, SC	ST, FC, SMA, SC	ST, FC, SMA, SC	ST, FC, SMA, SC
Weight kg	0.3	0.3	0.35	0.35	0.35
Compliance	CE, UKCA, China RoHS	CE, UKCA, China RoHS	CE, UKCA, China RoHS	CE, UKCA, China RoHS	CE, UKCA, China RoHS
Version	V1	V1	V1	V1	V1
Part number	<b>7Z07122</b>	<b>7Z02786</b>	<b>7Z07118</b>	<b>7Z02785</b>	<b>7Z02737</b>

Notes: (a) Above 1.1 $\mu\text{m}$  there is an additional calibration uncertainty of up to 2%.

Notes: (b) Long pulses (0.5 – 4s) can be used to measure power of high power lasers by measuring the energy of a short exposure. The StarBright, Juno, Juno+, Juno-RS and Centauri meters have a Pulsed Power mode where the user may specify the pulse width and get a reading directly in units of power for this short exposure energy measurement. See also page 107

Notes: (c) Powers up to 4000W can be measured. Recommended exposure times and 1/e<sup>2</sup> Gaussian beam diameters for very long pulses. Total energy for a series of measurements should not exceed 15kJ. Recommended time between shots 12s.

Notes: (d) Calibrated for 0.25 – 2 $\mu\text{m}$ , 10.6 $\mu\text{m}$

Notes: (e) For 10-50Hz, derate as follows:

Wavelength	Derate to value
1064nm	Not derated
532nm	Not derated
355nm	70% of stated value
266nm	15% of stated value
193nm	10% of stated value

Notes: (f) Damage threshold 1.5J/cm<sup>2</sup> for wavelengths <500nm

Notes: (g)  $\pm 4\%$ . For wavelengths <240nm

\* For drawings please see page 59

30(150)A-BB-18 / 30(150)A-LP2-18

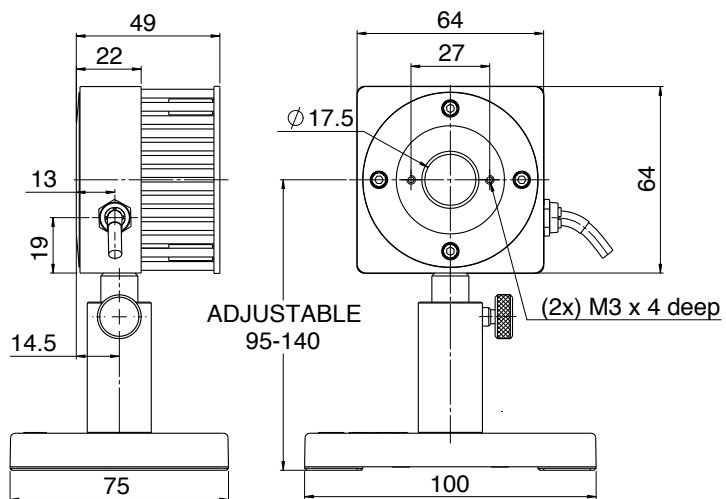

L50(150)A-BB-35 / L50(150)A-LP2-35 / L50(150)A-PF-35

