

H2-AF Hydrogen Sensor

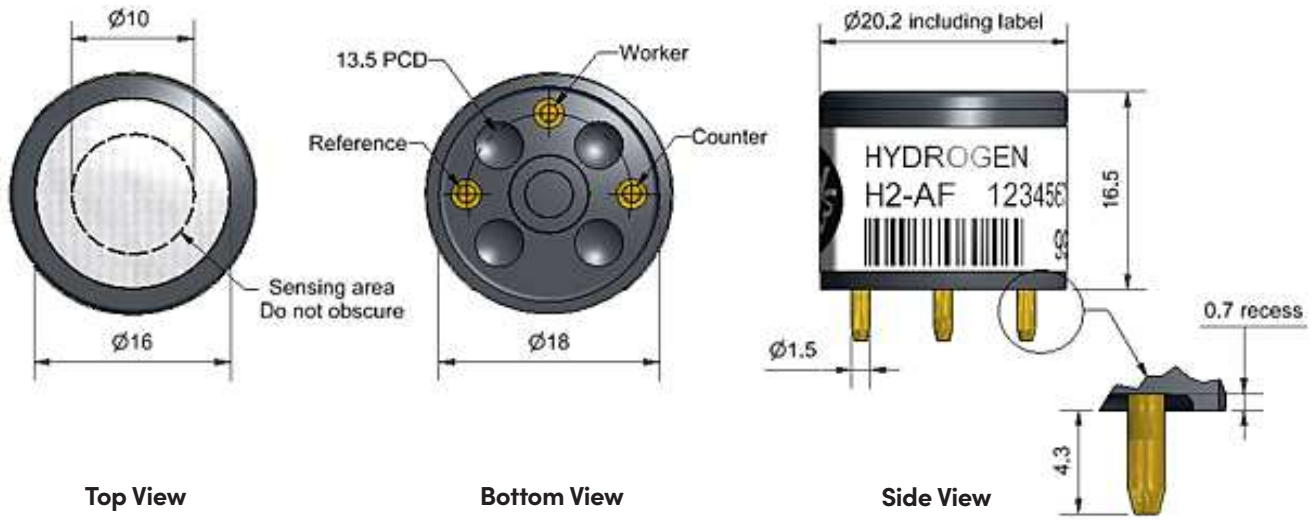

Dimensions are in millimetres (± 0.1 mm) unless otherwise stated.

Performance	Sensitivity	nA/ppm in 400ppm H ₂ at 23°C	10 to 40	
	Response time	t90 (s) from zero to 400ppm H ₂	< 35	
	Zero current	ppm equivalent in zero air	-25 to 15	
	Resolution	RMS noise (ppm equivalent)	< 0.7	
	Range	ppm H ₂ limit of performance warranty	2,000	
	Linearity	ppm error at full scale, linear at zero and 400ppm H ₂	-200 to -500	
	Overgas limit	maximum ppm for stable response to gas pulse	5,000	
	Lifetime	Zero drift	ppm equivalent change/year in lab air	< 20
Sensitivity drift		% change/year in lab air, monthly test	nd	
Operating life		months until 80% original signal (24-month warranted)	> 24	
Environmental	Sensitivity @ -20°C	% (output @ -20°C/output @ 20°C) @ 500ppm H ₂	10 to 25	
	Sensitivity @ 50°C	% (output @ 50°C/output @ 20°C) @ 500ppm H ₂	220 to 275	
	Zero @ -20°C	ppm equivalent change from 20°C	± 2	
	Zero @ 50°C	ppm equivalent change from 20°C	0 to -4	
Cross Sensitivity	Filter capacity	ppm hrs	H ₂ S	nd
	CO sensitivity	% measured gas @ 400ppm	CO	< 2
	NO ₂ sensitivity	% measured gas @ 10ppm	NO ₂	< 1
	Cl ₂ sensitivity	% measured gas @ 10ppm	Cl ₂	< 1
	NO sensitivity	% measured gas @ 50ppm	NO	< 40
	SO ₂ sensitivity	% measured gas @ 20ppm	SO ₂	< 4
	H ₂ S sensitivity	% measured gas @ 20ppm	H ₂ S	< 2
	C ₂ H ₄ sensitivity	% measured gas @ 400ppm	C ₂ H ₄	< 25
	NH ₃ sensitivity	% measured gas @ 20ppm	NH ₃	< 1
CO ₂ sensitivity	% measured gas @ 5%	CO ₂	< 1	
Key Specifications	Temperature range	°C	-30 to 50	
	Pressure range	kPa	80 to 120	
	Humidity range	% rh	15 to 90	
	Storage period	months @ 3 to 20°C (stored in sealed pot)	6	
	Load resistor	Ω (recommended)	10 to 47	
	Weight	g	< 6	

Figure 1 Response to 400ppm H₂

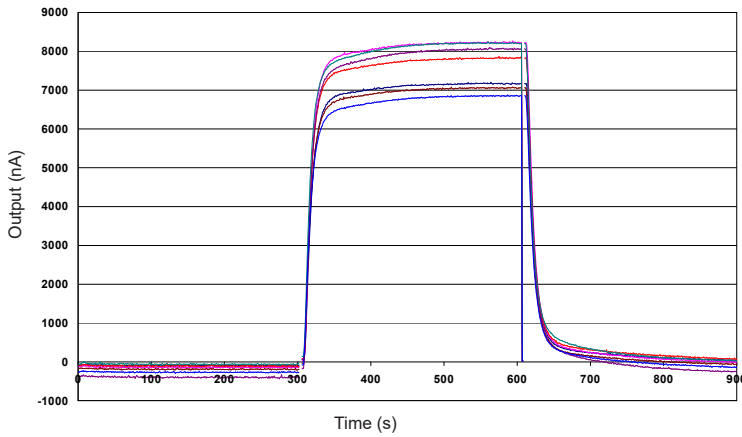

This hydrogen sensor shows a strong, repeatable response to hydrogen, combined with low sensitivity to CO.

Figure 2 Sensitivity Temperature Dependence

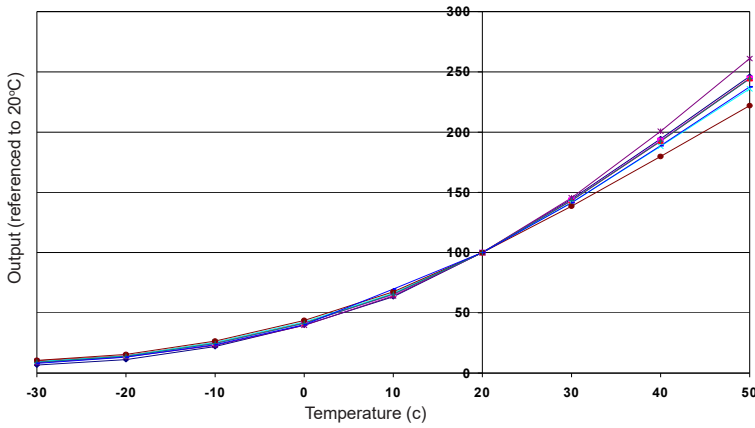

Figure 2 shows typical temperature dependence, measured at 1,000ppm H₂. This strong temperature dependence is very repeatable, so accurate temperature measurement ($\pm 0.5^\circ\text{C}$) is needed.

Figure 3 Zero Current Temperature Dependence

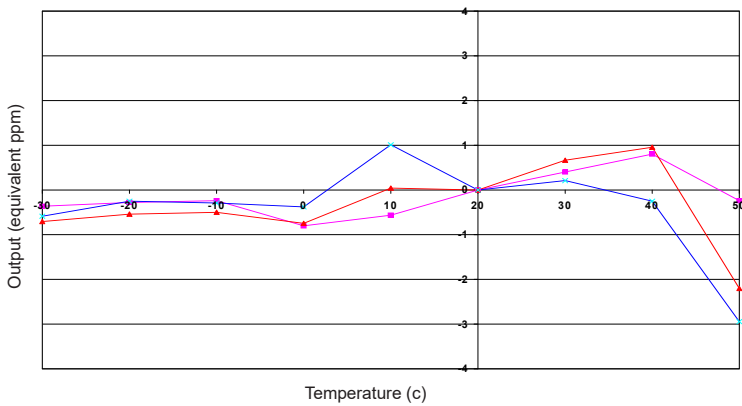

Figure 3 shows typical zero current from -30°C to $+50^\circ\text{C}$, expressed as equivalent ppm deviation from the zero current at 20°C .

At the end of the product's life, do not dispose of any electronic sensor, component or instrument in the domestic waste, but contact the instrument manufacturer, Alphasense or its distributor for disposal instructions. NOTE: all sensors are tested at ambient environmental conditions unless otherwise stated. As applications of use are outside our control, the information provided is given without legal responsibility. Customers should test under their own conditions, to ensure that the sensors are suitable for their own requirements.

In the interest of continued product improvement, we reserve the right to change design features and specifications without prior notification. The data contained in this document is for guidance only. Alphasense Ltd accepts no liability for any consequential losses, injury or damage resulting from the use of this document or the information contained within. (©ALPHASENSE LTD) Doc. Ref. H2-AF/FEB23